

A Transformerless 25-Watt Amplifier for Conventional Loudspeakers

D: P. DICKIE, JR.* AND A. MACOVSKI**

A Low-Cost, High-Quality Amplifier Using No Iron-Cored Components

DURING THE PAST SEVERAL YEARS audio amplifier design has progressed at a rate second only to that of the transducers associated with it in typical sound reproduction systems. A decade ago one could justifiably point to phonograph pickups and loudspeakers as the quality-determining links in the average home audio system. This disparity has been steadily narrowed and at the present time no one can generalize as to weak links. Suffice it to say that innovations in amplifiers have been less startling, since they had an initial jump on the rest of the elements involved in the sound reproduction process. Such advances as have been made center primarily about the output transformer. With minor exceptions, no basic circuit changes have found their way into commercially available amplifiers.

This attack on the problem was a logical one since only the transformers and the vacuum tubes in an amplifier can operate in a nonlinear fashion and thereby produce harmonic and intermodulation distortion. Furthermore, the fundamental limitations on bandwidth or frequency response have generally been due to the output transformer. One of the most practical ways to minimize harmonic distortion is to employ inverse feedback around those circuit elements that are responsible for the generation of distortion products. Again, the stumbling block has been the output transformer, for its high-frequency attenuation and phase shift characteristics have thus far limited the amount of inverse feedback which could be stably employed. This vicious circle has stimulated many inherent improvements in transformer design, but the fundamental problems still exist, although mitigated in magnitude. It is unfortunate but true that the

region of most serious distortion in a transformer is in the low- and very-low-frequency range. At these frequencies the magnetizing current may become sufficiently high to produce saturation flux densities in the core. Although inverse feedback can substantially reduce the distortion in the near-saturation region, its application is dependent upon the high- as well as the low-frequency characteristics of the transformer. There is no simple solution to the problem and careful attention must be paid to the sometimes conflicting demands of good high- and low-frequency performance. It should be pointed out here that the problem is not merely confined to frequency response of the transformer. Most good output transformers exhibit a frequency response far wider than that needed for sound reproduction. The problem of being able to transfer large amounts of power without distortion, particularly at the low-frequency end of the range, is another issue altogether.

Still another limitation imposed by most output transformers in high-quality systems is inability to operate well in class-B and AB power-amplifier stages. Unless there is a very high co-efficient of coupling between the two halves of the primary, transient signals are generated by the nonsinusoidal currents which flow in the half-primaries. Class-B and AB operation can contribute greatly to the power handling capabilities of an amplifier stage, but unfortunately these classes of operation have become associated with higher distortion. While this is fundamentally true, the amount of distortion is not serious and if sufficient inverse feedback is employed the output signal will be a good replica of the input. Full realization of these more efficient operating conditions must await the practical application of large amounts of inverse feedback.

The Transformerless Amplifier

With these problems of output transformers in mind many have envisaged transformerless amplifiers. While many of the problems associated with transformerless design seem overwhelming, at least one manufacturer has licked the biggest problem by winding a 500-ohm voice coil for his loudspeakers. Performance is almost unbelievable in those regions where transformer-type amplifiers fall down. It was felt by the writers that if outstanding performance could be obtained in a transformerless amplifier which could drive loudspeakers of conventional impedances, a very practical unit might be the result.

At the outset of study of the problem it was determined that any design should be a practical one. The use of transmitting-type tubes or inordinate quantities of receiving-type tubes was not justifiable. Plate efficiencies comparable to existing high-quality amplifiers should be achieved. Size, cost and weight should not exceed those of comparable amplifiers. Furthermore, it was felt that for a real contribution to be made, very exceptional operation should be the rule not only in the usual respects but particularly in those respects where transformer-type operation has its weaknesses. Since most high-quality loudspeakers are available in 16-ohm impedances, this amplifier was designed for that impedance. Following standard practice, the entire unit was designed for use with preamplifiers suitably equalized for the particular program source and capable of delivering 1 volt of signal.

Preliminary study yielded some startling results. It seemed that the unconventionality of the goal—that of driving a low-impedance speaker directly—ac-

* Pacific Mercury Television Mfg. Corp., 5955 Van Nuys Blvd., Van Nuys, Calif.

** RCA Laboratories, 711 Fifth Ave., New York 22, N. Y.

¹Chai Yeh, "Analysis of a single-ended push-pull audio amplifier," *Proc. IRE*, June 1953.

tually set off a chain reaction of further innovations. While most of the features ultimately used are tried and true procedures in the electronic industry, this particular combination of them is new to audio. The infusion of new blood seems to produce a healthy new approach to an old problem.

Theory Of Operation

The output stage of the amplifier is the single-ended, push-pull type as shown in Fig. 1.¹ The quiescent current is equal in both sets of triodes, with no d.c. flowing through the load. The tubes are driven out of phase with the difference in current between the tubes flowing through the speaker load.

The most efficient method of utilizing this system is to bias the output tubes close to cutoff with the operation approaching that of class B. The usual objections to this mode of operation, such as switching transients and distortion, do not apply if no output transformer is used. Class-B operation provides maximum power output with minimum plate dissipation so that the peak current capabilities of tubes can effectively be used. A low-impedance power supply is necessary with this arrangement so that the supply voltage will not drop excessively when the maximum current is drawn and thereby reduce the maximum power output.

The power supplies used are half-wave selenium rectifier circuits developing +140 v. and -140 v. with respect

to ground. These use large capacitors, with no additional filtering which would raise the power-supply impedance. To get higher voltages for low-level stages, additional selenium rectifiers are used in voltage adding arrangements to obtain 250 volts as shown in Fig. 1.

The absence of an output transformer allows 40 db of feedback to be applied by connecting the voice coil directly to the cathode of the phase splitter driver. Besides its distortion reduction characteristic, the application of feedback serves to reduce drastically the hum voltage which would otherwise be present. Since the gain within the feedback loop is essentially unity, an additional voltage amplifier is used, with separate feedback, to build up the input voltage to the voice-coil level.

Circuit Details

Figure 1 shows the final circuit of the amplifier. Three 6082 double triodes are used. They are 26.5-volt versions of the popular 6AS7G. These tubes are capable of 700 ma of peak current per triode section at the plate voltages used. The 6082's allow the use of a series heater string, eliminating a filament transformer. The tubes cut off at about 70 volts, and a 60-volt fixed bias is used on each. The bias on one side is made adjustable so as to equalize the d.c. in the two sets of triodes and insure that no d.c. flows in the voice coil. To protect the tubes, a low d.c. impedance of 56,000 ohms is used in the grid circuit.

It should be noted that the 6082 is not intended for use with fixed bias unless a limiting resistor is added in either the plate or the cathode circuit of the tube. Although this circuit does not use such resistors, their omission is feasible because the tubes are used under quiescent conditions well below maximum ratings.

The voltage-amplifier stages are all operated class A with conventional circuitry. A separate driver is needed for each side of the output tubes, since insufficient output is obtained from the phase splitter to drive the output tubes directly. One side of the phase splitter has a larger load than the other, since the input to the lower group of output tubes has the speaker impedance in the cathode. This causes degeneration and necessitates higher input than the upper group. In the first voltage amplifier, bias is obtained using unbypassed cathode resistors since the loss in gain can easily be tolerated. The phase-splitter driver, however, has fixed bias applied to its grid by dividing down from the -140-volt bus, since maximum gain is desired within the main feedback loop.

The high-current power supplies use 300- μ f capacitors and 5-ohm protective resistors (each made up of paralleled 10-ohm units). A voltage adder circuit is used for the -250-volt supply, which supplies only bias. Another voltage adder circuit is used to supply +250 volts for the driver stages. Additional R-C decoupling is used to minimize hum in the low-level stages.

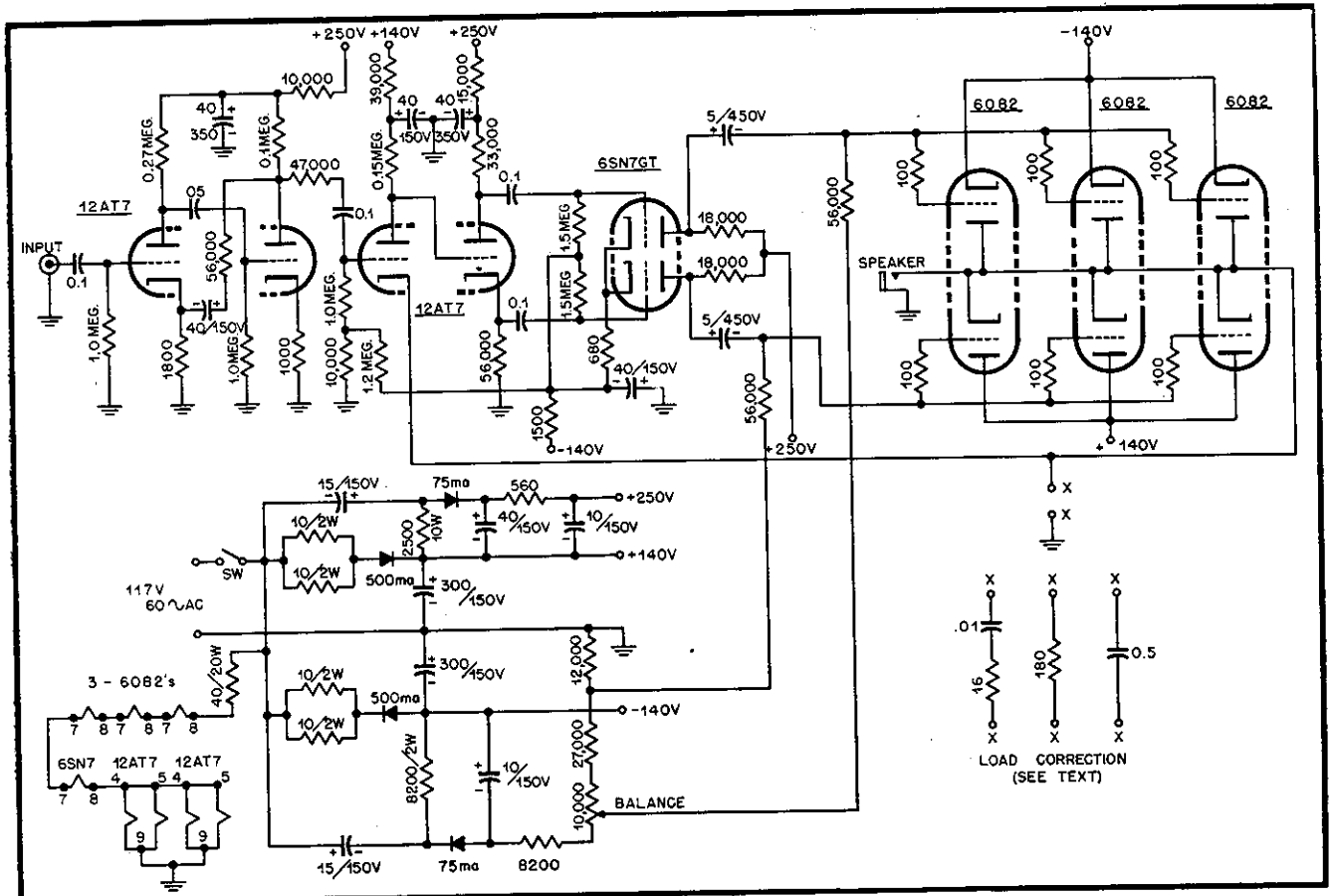

Fig. 1. This is the complete schematic diagram of the transformerless amplifier. Its total cost is comparable to that of a single high-quality output transformer. For safety, use of a 1-to-1 isolation transformer is recommended between the a.c. line and the power input terminals.

Operational Details

As with all power-transformerless equipment, care must be used when connecting to other pieces of equipment to see that the cold side of the line is connected to the chassis. Although this is readily achieved, the use of a small power line isolation transformer would eliminate the need for caution.

As would be expected, 40 db of feedback can be applied only within a loop having a minimum of phase shifts to avoid instability. It is therefore necessary to modify the arrangement when using speakers which present other than a resistive load to the amplifier. This situation is not generally encountered in transformer-type amplifiers since the output transformer itself becomes the main impedance at high frequencies. That is, the speaker high-frequency impedance is not reflected through the transformer. Figure 1 shows three alternative ways to deal with instability due to an inductive speaker load, which not only causes additional phase shift, but causes higher amounts of feedback due to the increased load impedance. The 180-ohm resistor merely limits the maximum impedance of the speaker and thus prevents excessive feedback. The 0.5- μ f capacitor is a low impedance at high frequencies, shorting the inductive load. The series 16-ohm resistor and .01- μ f capacitor places a 16-ohm resistor across the speaker at high frequencies and an open circuit at low frequencies. This serves to provide constant impedance and feedback over the frequency range. If any instability is noted with a given speaker, try one or the other for best operation.

The balance adjustment for zero d.c. in the voice coil can be made with a milliammeter in series with the voice coil (a closed-circuit jack might be added for the purpose). It should be repeated when tubes are changed or after many months of operation.

Performance

The operational results of the prototype model of this amplifier are shown by the curves and photographs.

The frequency response, which is shown in Fig. 2, is flat over a very wide range. Since resistive-capacitance-coupled circuits are used throughout, there is no serious limitation on response. To keep circuit complexity down, and to achieve the best feedback stability, a reasonable amount of gain per stage is desired. This, of course, will determine the high-frequency limitations, while the interstage coupling networks determine the low-frequencies limitations. While the bandwidth without feedback would be wide in this design, the use of 40 db of inverse feedback extends the ends of the range manyfold. Most good amplifiers exhibit a flat response well beyond the limits of audibility, and this unit probably ranks as one of the widest-band designs intended for audio use.

As shown in Fig. 3, the harmonic distortion even at full rated output is exceptionally low and virtually independent of frequency. The ability to deliver 25 watts at 20 cycles and below

with negligible distortion is practically impossible in a transformer-type amplifier of similar mid-frequency power rating. The low-frequency performance is directly attributable to the use of circuit components whose nonlinear properties are in no way dependent upon

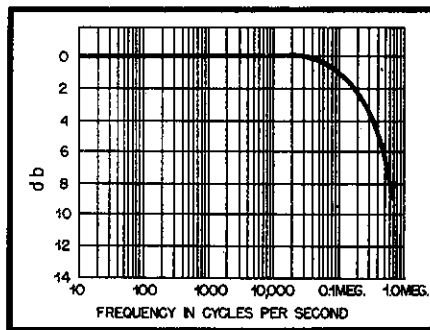

Fig. 2. Frequency response of this amplifier is flat at the low end and less than 3 db down at 200,000 cps, making it one of the widest-band designs in use today for audio.

frequency. Thus the 40 db of feedback remains at that value over the entire usable frequency range and satisfactorily reduces the distortion without regard to the frequencies involved. Even if the distortion in the amplifier without feedback were as high as 10 per cent, the 40-db figure, corresponding to a voltage ratio of 100 to one, would reduce this to 0.1 per cent.

While dealing with the tested results it is worthwhile to mention the subject of intermodulation distortion. IM is a very good and rapid means of evaluating distortion in an amplifier. It is, however, at its greatest value in testing systems where there is apt to be a marked dissimilarity in the nonlinear performance of the amplifier at the particular pair of frequencies used in the test. In an amplifier such as this where there is no frequency-sensitive distortion characteristic, IM testing would yield little to the total fund of information.

The efficiency with which a 16-ohm loudspeaker may be driven directly to produce these large power outputs is due not only to the extremely high permeance of the output tubes but also to operation approaching class B. Sufficient quiescent current flows in each tube to ensure good small-signal linearity. That is, the

operating bias is sufficiently low to ensure that the no-signal operating point is outside the curved region of the tube characteristic near plate-current cutoff. The resulting efficiency is about the same as a transformer-type class-A amplifier.

The square-wave performance of an amplifier is an indication of its ability to reproduce signals of a transient nature. The low-frequency square-wave response is a measure of the ability to reproduce extremely low frequencies. The amount of "droop" in the square-wave response is the important feature in this respect. A negligible droop at a particular square-wave frequency means that the amplifier will reproduce well down to frequencies which are only a fraction of the fundamental. The loudspeaker damping, however, will probably be the ultimate factor in low-frequency transient performance. While it is impossible to secure unlimited amounts of damping through reduction of the output impedance of the amplifier, it is im-

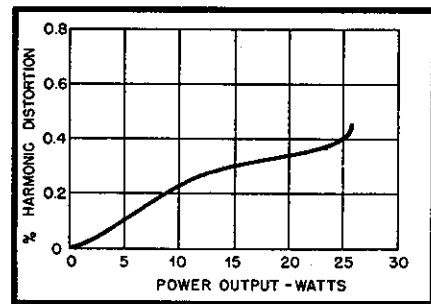

Fig. 3. Harmonic distortion is less than 0.4 per cent at the related output of 20 watts into a 16-ohm speaker. Intermodulation measurements would mean little since there are no frequency-sensitive nonlinear elements in the design.

portant that this internal impedance be at least several times lower than the speaker's nominal impedance. Reductions of amplifier internal impedance beyond this point are not necessary but can do no harm. The internal impedance of this amplifier, due to the large amount of feedback, is only a fraction of an ohm. This provides excellent electrical damping.

The high-frequency square-wave performance is a good indication, not only of transient response, but also of the stability of the feedback system. A

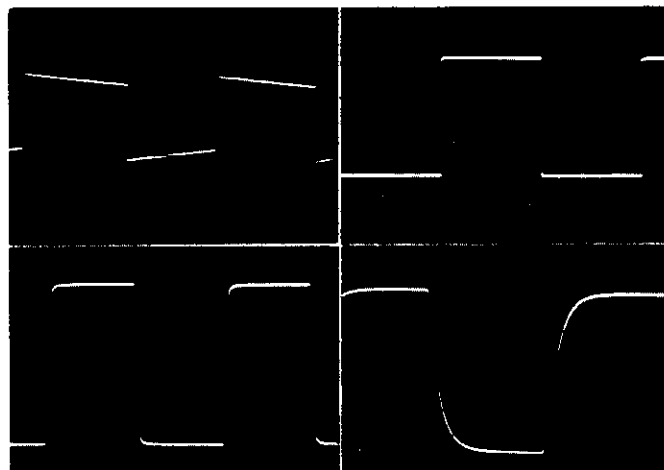

Fig. 4. These photos of oscilloscope traces show square-wave response at four frequencies—top row, left to right, 20 and 1000 cps; bottom row, 10,000 and 50,000 cps. Note the unusually short rise time even at 10,000 cps and the complete absence of evidences of instability despite a full 40 db of feedback. Effective output impedance is a fraction of an ohm, eliminating any tendency toward overshoot on transients.

tendency towards instability (not necessarily oscillation) will manifest itself as a decaying train of oscillations following the rapid rise and fall of the square wave. Of course, if these oscillating overshoots do not decay or die out, the system will oscillate continuously. It is important to have ample stability in the feedback system to prevent any form of "ringing" or overshoot on a rapidly rising square wave. The actual rise time of the square wave itself in the output is largely a measure of the high-frequency response.

Several square-wave frequencies are shown in *Fig. 4*. Although the highest frequency shown (50 kc) is only of academic interest, it was included to indicate that the performance was not greatly deteriorated at a high frequency ordinarily used to test video amplifiers.

The extremely light weight and small size as well as the low cost of this amplifier stem principally from the absence of heavy and costly components. The only items of major expense are the tubes, the four selenium rectifiers, and the two large electrolytic capacitors. The remaining components are small resistors and capacitors of the sort encountered in most amplifiers. The three output tubes are considerably more expensive than the normal receiving type, but are still reasonably priced. The other tubes are of widely used variety and inexpensive. Only two of the selenium rectifiers are the 500-ma type, while the other two are the small 75-ma variety. The total cost, computed from the catalog of a large parts supplier, is approximately the same as that of a single high-quality output transformer of the type

originally designed for a currently popular amplifier.

The hum level in this amplifier is about .02 volt across the load. This is 60 db below the rated power output. This value was found to be exceeded by the extraneous hum of the supplied source material from the preamplifier, which in itself was acceptably low.

The qualitative results of an amplifier are generally the results of listening tests. While it is impossible to attribute specific attributes of good reproduction to particular links in the system merely by listening, some indication of performance may be had by comparative methods. As one would suspect from the features, the way in which this design excels is when handling large amounts of power at low frequencies. Even at moderate listening levels, an exceptional clearness of reproduction was noted on organ music. An RCA LC-1A in its standard studio console phase-inverter cabinet was used for listening tests. It was neither feasible nor desirable to employ anything near the full output of this amplifier with this loudspeaker, but at reasonably high room levels, the low-frequency reproduction seemed exceptionally smooth and realistic. The use of a horn-type low-frequency loudspeaker, which would more efficiently load the cone, would permit the use of higher and more realistic levels of, say, a pipe organ. While this has not been tried, it is thought that here is where the amplifier would excel. Since it is capable of delivering large amounts of low-frequency power, low-frequency signals such as those developed when tuning through an FM

signal may cause excessive cone excursions in speakers which are inadequately coupled to the air. If such is the case, the coupling capacitor between the first and second 12AT7's may be reduced to attenuate these effects.

PARTS LIST

Capacitors

1	.05	µf,	600	v.	paper
4	0.1	µf,	600	v.	paper
2	10	µf,	150	v.	electrolytic
2	15	µf,	150	v.	electrolytic
3	40	µf,	150	v.	electrolytic
2	300	µf,	150	v.	electrolytic
3	40	µf,	350	v.	electrolytic
2	5	µf,	450	v.	electrolytic

Resistors

		1-watt	
6	100	ohms	1 39,000 ohms
1	680	ohms	1 47,000 ohms
1	1000	ohms	4 56,000 ohms
1	1500	ohms	1 0.1 meg
1	1800	ohms	1 0.15 meg
2	10,000	ohms	1 0.27 meg
1	15,000	ohms	3 1.0 meg
2	18,000	ohms	1 1.2 meg
1	33,000	ohms	2 1.5 meg

2-watt

4	10	ohms	1 12,000 ohms
1	560	ohms	1 27,000 ohms
2	8200	ohms	

10-watt

1	2500	ohms	
---	------	------	--

20-watt

1	40	ohms	
---	----	------	--

1	10,000-ohm	wirewound potentiometer
2	75-ma,	130-volt selenium rectifiers
2	500-ma,	130-volt selenium rectifiers
1	6SN7	
2	12AT7's	
3	6082's	